









# 2

## SUCTION CUPS

	<i>Flat suction cup FS-G 10 to G 60</i>	2.2
	<i>Flat suction cup FS-G 1,5 to G 95</i>	2.4
	<i>Flat suction cup FS-GR 75 to GR 115</i>	2.6
	<i>Flat suction cup FS-G 20 VU to G 100 VU</i>	2.8
	<i>Bellows type suction cup FBS-GF 30 to GF 115</i>	2.10
	<i>Bellows type suction cup FBS-GF 10 to GF 75</i>	2.12
	<i>Bellows type suction cup FBS-GF 20VU to GF 85VU</i>	2.14
	<i>Bellows type suction cup FBS-GFD 5 to GF 90</i>	2.16
	<i>Bellows type suction cup FBS-GFD 20 VU to 85 VU</i>	2.18

**Description**

Very elastic rubber suction cup for sticking onto connection nipples. Suitable for holding or transporting small parts, thin-walled materials with even or slightly uneven surface or large-surface parts as thin sheet metals, plastics, etc. When worn out, the suction cup can just be pulled off the connection nipple and replaced by a new one.



Suction cup G 38-CR-W



Suction cup GN with nipples

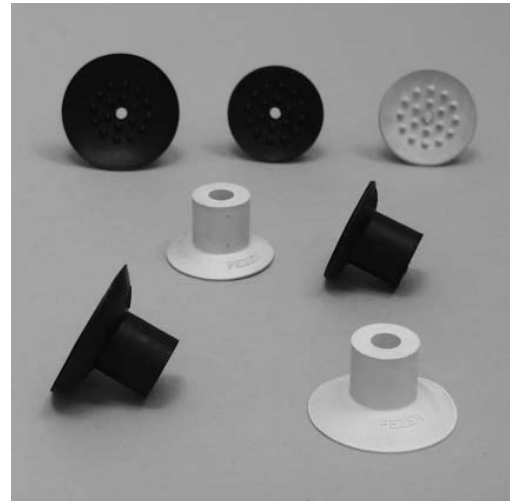

Suction cup G 10 - G 60

Type	NBR-S	SI-T	CR-W	Connection nipple	
				1/4-A	M 5-A
FS-G 10	1.01.1.0004	1.01.1.0007	1.01.1.0001	--	1.31.1.0002
FS-G 20	1.01.1.0017	1.01.1.0021	1.01.1.0015	1.31.1.0012	1.31.1.0011
FS-G 28	1.01.1.0030	1.01.1.0031	1.01.1.0029	1.31.1.0012	1.31.1.0011
FS-G 38	1.01.1.0050	1.01.1.0051	1.01.1.0049	1.31.1.0014	1.31.1.0013
FS-GN 38	1.01.1.0082	1.01.1.0083	1.01.1.0081	1.31.1.0014	1.31.1.0013
FS-G 47	1.01.1.0058	1.01.1.0059	1.01.1.0057	1.31.1.0014	1.31.1.0013
FS-GN 47	1.01.1.0085	1.01.1.0086	1.01.1.0084	1.31.1.0014	1.31.1.0013
FS-G 60	---	1.01.1.0072	1.01.1.0066	1.31.1.0006	1.31.1.0013

1) Please order connection nipples separately; article numbers only refer to suction cup without connection nipples. GN design with nipple sealing.

**Material:**

NBR-S Perbunane, black  
 SI-T Silicone, transparent  
 CR-W Neoprene, white

Technical Data				
Type	Hold. force <sup>2)</sup> (N)	Weight (g)	Volume <sup>3)</sup> (ml)	Bolt type
FS-G 10	3,9	1	0,02	STN-12
FS-G 20	13	6	0,1	STN-16
FS-G 28	20	7	4	STN-16
FS-G 38	46	14	4	STN-16
FS-GN 38	45	14	4	STN-16
FS-G 47	60	15	14	STN-16
FS-GN 47	61,5	15	14	STN-16
FS-G 60	93	22	16	STN-16

2) Holding Forces in N with operational vacuum of 60 % without safety margin relate to even, smooth and dry surfaces

3) Volume with suction cup in released condition

# FLAT SUCTION CUP G 10 - G 60, GN 38 - GN 47

(Perbunane, Silicone, Neoprene)

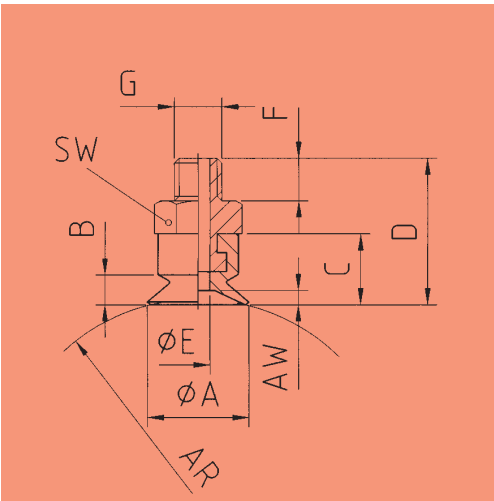

Suction cup G 10

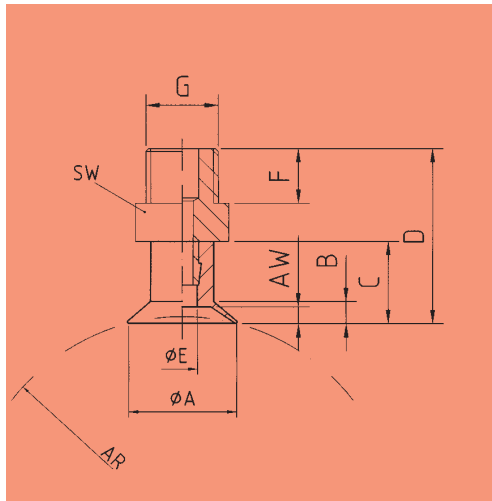

Suction cup G 20 - G 28

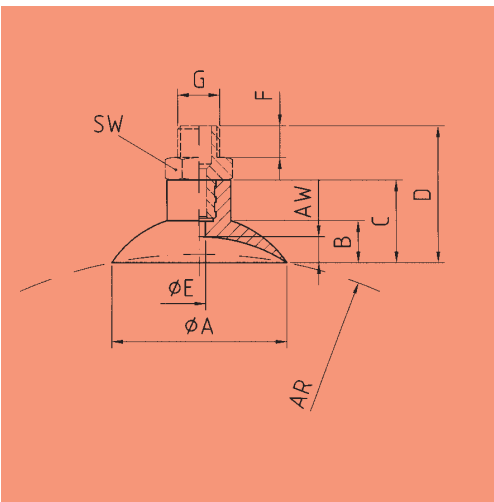

Suction cup G 38 - G 60

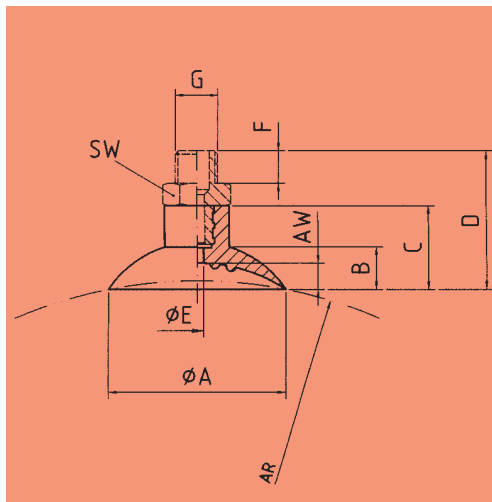

Suction cup GN 38 und GN 47

<b>Dimensions</b>										
Type	A	B	AW	AR	C	D	E	F	G	SW
FS-G 10	10	3,5	1,5	6	7,5	15,5	2,5	4,5	M 5	8
FS-G 20	20	4	3	15	15	32	5,5	10	R 1/4"	17
FS-G 28	28	4	3	20	15	32	5,5	6	R 1/4"	17
FS-G 38	38	6	3,5	30	23,5	40,5	4,5	10	R 1/4"	19
FS-GN 38	38	6	4	37	23,5	40,5	4,5	10	R 1/4"	19
FS-G 47	47	8	5,5	35	26	43	4,5	10	R 1/4"	19
FS-GN 47	47	8	6	37	26	43	4,5	10	R 1/4"	19
FS-G 60	55	13	8	35	26	43	4	10	R 1/4"	19

(Perbunane, Silicone, Neoprene, Polyurethane, Vitone)

**Description**

Very elastic rubber suction cup for sticking onto connection nipples. Suitable for holding or transporting small parts, thin-walled materials or plates.

Antistatic version suitable for electro- and electrical industry for furnishing printed circuit boards.

Suction cups made from polyurethane are very wear-resistant and are mainly used in long-time shifts. Suction cups made of FKM-AF (Vitone) are manufactured in imprint-free design.

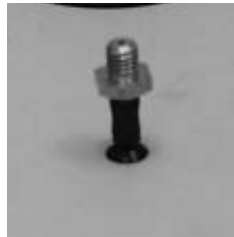

Suction cup G 5 with nipple



CD-Rom transport



Suction cup G 2 - G 20

**Technical Data**

Type	Hold. force <sup>2)</sup> (N)	Weight (g)	Volume <sup>3)</sup> (ml)	Bolt type	Connection nipple <sup>4)</sup>	
					M5-A	R1/4-A
FS-G 2	0,12	1	0,01	STN-12	1.31.1.0001	---
FS-G 3,5	0,45	1	0,01	STN-12	1.31.1.0001	---
FS-G 5	0,6	1	0,01	STN-12	1.31.1.0002	---
FS-G 6	0,9	1	0,01	STN-12	1.31.1.0002	---
FS-G 8	1,8	1	0,01	STN-12	1.31.1.0002	---
FS-G 10	3,9	1	0,02	STN-12	1.31.1.0002	---
FS-G 15	6	5	0,05	STN-12	1.31.1.0002	---
FS-G 20	12	6	0,1	STN-16	---	1.31.1.0005
FS-G 25	23	7	0,9	STN-16	---	1.31.1.0005
FS-G 30	33	8	1,5	STN-16	---	1.31.1.0005
FS-G 35	46	10	3,6	STN-16	---	1.31.1.0005
FS-G 40	62	12	5,5	STN-16	---	1.31.1.0005
FS-G 50	78	25	7,5	STN-16	---	1.31.1.0004
FS-G 60	139	34	12	STN-16	---	1.31.1.0006
FS-G 80	275	48	25	STN-16	---	1.31.1.0006
FS-G 95	360	62	40	STN-16	---	1.31.1.0006

2) Holding force in N at 60 % operational vacuum w/o safety factor for even, smooth and dry surfaces

3) Volume in disengaged, unloaded position of the suction cup

4) Connection nipple with different connections on request!

**Werkstoffe:**

- NBR-S Perbunane, black
- NBR-AS Perbunane antistatic, black
- SI-T Silicone, transparent
- SI-AS Silicone antistatic, black
- CR-GR Neoprene, green
- PU Polyurethane, blue
- FKM Vitone, black
- FKM-AF Vitone, imprint-free, black

# FLAT SUCTION CUP G 1,5 - G 95

(Perbunane, Silicone, Neoprene, Polyurethane, Vitone)

Article number								
Typ	NBR	NBR-AS	SI-T	SI-AS	CR	PU	FKM	FKM-AF
FS-G 2	1.01.1.0034	1.01.1.0033	1.01.1.0037	1.01.1.0036	1.01.1.0032	1.01.1.0035	1.01.1.0114	---
FS-G 3,5	1.01.1.0040	1.01.1.0039	1.01.1.0043	1.01.1.0042	1.01.1.0038	1.01.1.0041	1.01.1.0115	---
FS-G 5	1.01.1.0116	1.01.1.0117	1.01.1.0118	1.01.1.0119	1.01.1.0120	1.01.1.0121	1.01.1.0122	---
FS-G 6	1.01.1.0077	1.01.1.0075	1.01.1.0080	1.01.1.0079	1.01.1.0074	1.01.1.0078	1.01.1.0123	1.01.1.0131
FS-G 8	1.01.1.0124	1.01.1.0125	1.01.1.0126	1.01.1.0127	1.01.1.0128	1.01.1.0129	1.01.1.0130	1.01.1.0132
FS-G 10	1.01.1.0004	1.01.1.0133	1.01.1.0007	1.01.1.0006	1.01.1.0001	1.01.1.0005	1.01.1.0134	1.01.1.0135
FS-G 15	1.01.1.0010	1.01.1.0009	1.01.1.0013	1.01.1.0012	1.01.1.0008	1.01.1.0011	1.01.1.0136	1.01.1.0137
FS-G 20	1.01.1.0017	1.01.1.0016	1.01.1.0021	1.01.1.0020	1.01.1.0015	1.01.1.0019	1.01.1.0138	1.01.1.0139
FS-G 25	1.01.1.0140	1.01.1.0141	1.01.1.0142	1.01.1.0143	1.01.1.0144	1.01.1.0145	1.01.1.0146	1.01.1.0147
FS-G 30	1.01.1.0148	1.01.1.0044	1.01.1.0149	1.01.1.0047	1.01.1.0150	1.01.1.0046	1.01.1.0151	1.01.1.0152
FS-G 35	1.01.1.0153	1.01.1.0154	1.01.1.0155	1.01.1.0156	1.01.1.0157	1.01.1.0158	1.01.1.0159	1.01.1.0160
FS-G 40	1.01.1.0161	1.01.1.0053	1.01.1.0162	1.01.1.0056	1.01.1.0163	1.01.1.0055	1.01.1.0164	1.01.1.0165
FS-G 50	1.01.1.0166	1.01.1.0061	1.01.1.0167	1.01.1.0064	1.01.1.0168	1.01.1.0063	1.01.1.0169	1.01.1.0170
FS-G 60	1.01.1.0171	1.01.1.0067	1.01.1.0172	1.01.1.0071	1.01.1.0173	1.01.1.0070	1.01.1.0174	1.01.1.0175
FS-G 80	1.01.1.0176	1.01.1.0177	1.01.1.0178	1.01.1.0179	1.01.1.0180	1.01.1.0181	1.01.1.0182	1.01.1.0183
FS-G 95	1.01.1.0184	1.01.1.0185	1.01.1.0186	1.01.1.0187	1.01.1.0188	1.01.1.0189	1.01.1.0190	1.01.1.0192

1) Please order connection nipple separately, Article number only refers to suction cup w/o connection nipple.

Abmessungen										
Typ	A	B	AW	AR	C	D	E	F	G	SW
FS-G 2	2	---	0,5	2	2,5	12	2,5	4,5	M 5	8
FS-G 3,5	3,5	---	0,5	4	2,5	12	2,5	4,5	M 5	8
FS-G 5	5	2	0,5	5	4	14,5	2,5	4,5	M 5	8
FS-G 6	6	2	0,8	5	4	14,5	2,5	4,5	M 5	8
FS-G 8	8	3	1	6	5,5	15,5	2,5	4,5	M 5	8
FS-G 10	10	3,5	1,5	6	8	16	2,5	4,5	M 5	8
FS-G 15	15	4	2	8	8	16	2,5	4,5	M 5	8
FS-G 20	20	5,5	2	15	10	27,5	3	10	G 1/4"	17
FS-G 25	25	7	2	20	14	29	4	10	G 1/4"	17
FS-G 30	29	7	1,7	25	12	27	4	10	G 1/4"	17
FS-G 35	35	7	3	30	14	29	4	10	G 1/4"	17
FS-G 40	40	8	3,8	35	14	29	4	10	G 1/4"	17
FS-G 50	50	8,5	3,8	50	14	30	4	10	G 1/4"	17
FS-G 60	60	8,5	5	80	18	33	5,5	10	G 1/4"	17
FS-G 80	80	12	6	150	21	36	5,5	10	G 1/4"	17
FS-G 95	100	12	6	250	21	36	5,5	10	G 1/4"	17

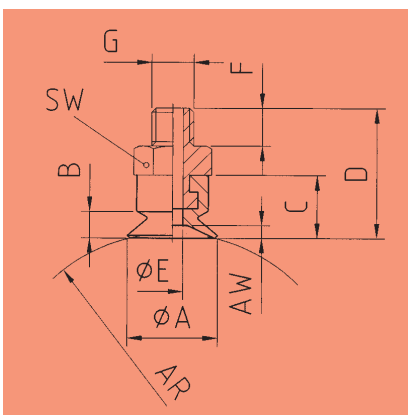

Suction cup G 2 - G 16

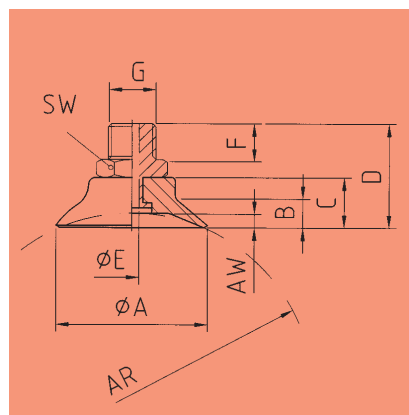

Suction cup G 20 - G 50

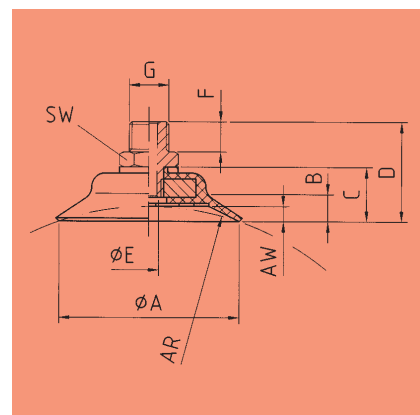

Suction cup G 60 - G 95

**Description**

Very robust and versatile suction cup with connection nipple vulcanized into it. A grooved lining supports the entire suction surface. Suitable for material with smooth and even surface. Because of the grooved lining especially suitable for vertical applications and ones with very high cross accelerations.

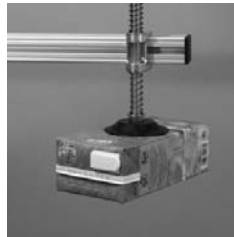

Suction cup GR 95



Suction cup GR view from below



Suction cup GR

**Materials :**

- NBR-S Perbunane, black
- NBR-S Perbunane, grey
- SI-T Silicone, transparent

**Article numbers**

Type	NBR-S	NBR-G	SI-T	Conn. nipple
FS-GR 75	1.01.2.0006	1.01.2.0005	1.01.2.0007	vulcanized
FS-GR 95	1.01.2.0010	1.01.2.0008	1.01.2.0011	vulcanized
FS-GR 115	1.01.2.0003	1.01.2.0002	1.01.2.0004	vulcanized

**Technical Data**

Type	Hold.force <sup>2)</sup> (N)	Weight (g)	Volume <sup>3)</sup> (ml)	Bolt type
FS-GR 75	169,5	60	30	STN-16
FS-GR 95	270	90	40	STN-16
FS-GR 115	379,5	130	60	STN-16

2) Holding forces in N at 60 % operational vacuum without safety factor, on even, smooth and dry surfaces

3) Volume in released, unloaded condition of the suction cup

# FLAT SUCTION CUP GR 75 - GR 115

(Perbunane, Silicone, Neoprene)

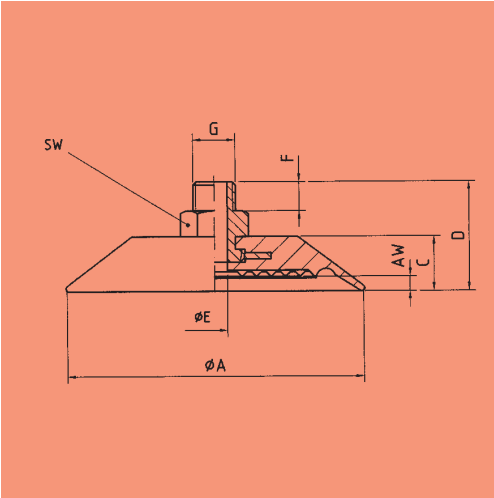

Dimension								
Type	A	AW	C	D	E	F	G	SW
FS-GR 75	73	4,5	17	34	8	9	R 1/4"	19
FS-GR 95	93	4,5	17	34	8	9	R 1/4"	19
FS-GR 115	113	5	17	34	8	9	R 1/4"	19

**Description**

Very robust and extremely resistant suction cup made of vulkollane. Vulkollane has an up to 10 times higher life time is especially suitable for use in multi-shift operations. Mainly suitable in automated processes and in the plastic and packing industries. After they are worn out they can be easily removed from the connection nipple and replaced.

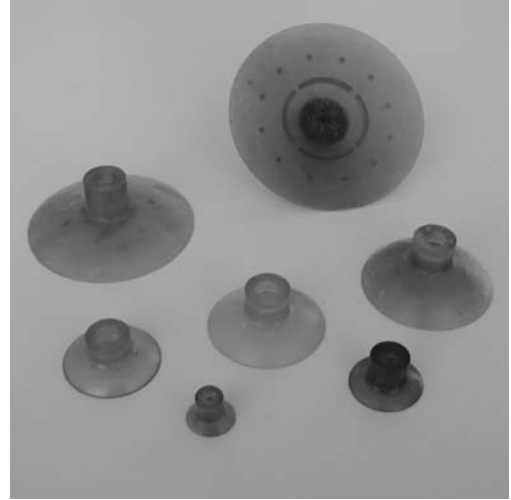

Suction cup G 20 VU - G 100 VU made of vulkollane

**Materials:**

VU-BR Vulkollane brown

**Article numbers**

Type	VU-BR	conn. nipple 1/8-A	conn. nipple 1/4-A
FS-G 20 VU	1.01.1.0100	1.31.1.0018	---
FS-G 30 VU	1.01.1.0101	1.31.1.0018	---
FS-G 40 VU	1.01.1.0102	---	1.31.1.0019
FS-G 50 VU	1.01.1.0103	---	1.31.1.0019
FS-G 60 VU	1.01.1.0104	---	1.31.1.0019
FS-G 80 VU	1.01.1.0105	---	1.31.1.0019
FS-G 100 VU	1.01.1.0106	---	1.31.1.0019

1) Please order connection nipples separately; article numbers only refer to suction cup without connection nipples.

**Technical Data**

Type	Hold. force <sup>2)</sup> (N)	Weight (g)	Volume <sup>3)</sup> (ml)	Bolt type
FS-G 20 VU	16	8	0,3	STN-12
FS-G 30 VU	45	12	2,8	STN-12
FS-G 40 VU	68	14	5,8	STN-16
FS-G 50 VU	82	25	9,0	STN-16
FS-G 60 VU	128	34	16	STN-16
FS-G 80 VU	225	85	63	STN-16
FS-G 100 VU	300	120	180	STN-16

2) Holding forces in N at 60 % operational vacuum without safety factor, on even, smooth and dry surfaces

3) Volume in released, unloaded condition of the suction cup

# FLAT SUCTION CUP G 20 - G 100

Vulkollane

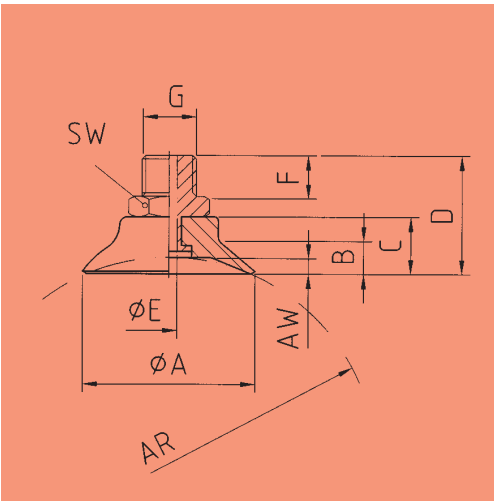

Suction cup G 20 - G 30 VU

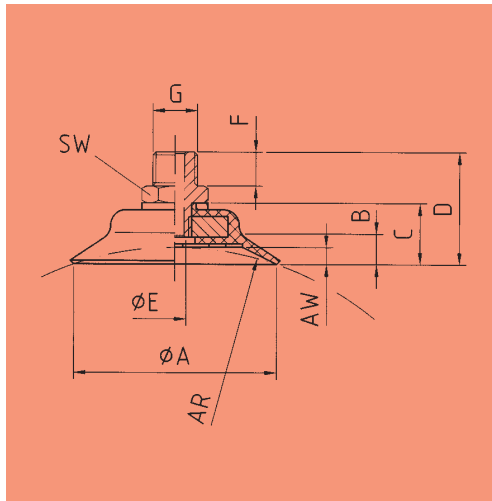

Suction cup G 40 - G 100 VU

Suction cup 2

<b>Dimensions</b>										
Type	A	B	AW	AR	C	D	E	F	G	SW
FS-G 20 VU	20	8	9	15	13	28,5	3	9,5	G 1/8	14
FS-G 30 VU	30	10	14	25	17	32,5	3	9,5	G 1/8	14
FS-G 40 VU	40	7	11	35	17	35	6	10	G 1/4	17
FS-G 50 VU	50	12	16	50	22	40	6	10	G 1/4	17
FS-G 60 VU	60	17	20	80	27	45	6	10	G 1/4	17
FS-G 80 VU	80	12	19	160	26	44	6	10	G 1/4	17
FS-G 100 VU	100	22	22	340	32	50	6	10	G 1/4	17

**Description**

Very robust and wear-resistant suction cup with 1.5 creases. Suitable for thin-walled materials with smooth or formed surface. Because of the suspension of the suction cup, it is especially suitable for sensitive transporting goods. Because of the elasticity of the creases the suction cup adjusts to the work piece in every situation. Creases pull together when suction process is activated (relatively high suction way).

Suction cup 2



Cups GF 95 and GF 115



Cup GF 55



Cup GF

**Materials:**

NBR-S Perbunane, black  
 SI-R Silicone, red

**Article numbers**

Type	NBR-S	SI-R	conn. nipple R 1/4"-A
FBS-GF 30	1.02.1.0018	1.02.1.0021	1.31.1.0014
FBS-GF 55	1.02.1.0028	1.02.1.0031	1.31.1.0014
FBS-GF 75	1.02.1.0034	1.02.1.0037	1.31.1.0014
FBS-GF 95	1.02.2.0003	---	vulcanized
FBS-GF 115	1.02.2.0001	---	vulcanized

1) Please order connection nipples separately; article numbers only refer to suction cup without connection nipples.

**Technical Data**

Type	Hold. force <sup>2)</sup> (N)	Weight (g)	Volume <sup>3)</sup> (ml)	Bolt type
FBS-GF 30	26	13	8	STN-16
FBS-GF 55	57	31	35	STN-16
FBS-GF 75	92	90	100	STN-16
FBS-GF 95	171	100	100	STN-16
FBS-GF 115	320	200	210	STN-16

2) Holding forces in N at 60 % operational vacuum without safety factor, on even, smooth and dry surfaces

3) Volume in released, unloaded condition of the suction cup

# BELLOWS TYPE CUP 30 - GF 115

(Perbunane, Silicone, Neoprene)

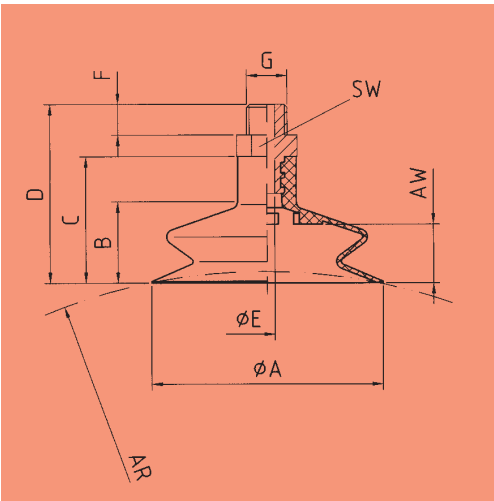

Bellows type cups GF 30, GF 55, GF 75

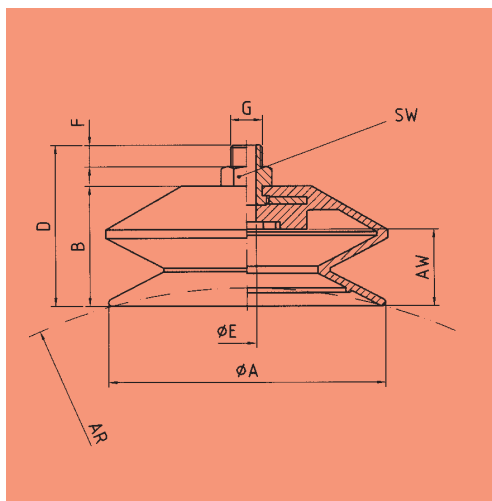

Bellows type cups GF 95 und GF 115

**Suction cup 2**

<b>Dimensions</b>										
Type	A	B	AW	AR	C	D	E	F	G	SW
FBS-GF 30	30	15	11	12	31	48	5	10	R 1/4"	19
FBS-GF 55	55	24	15	30	41	58	5	10	R 1/4"	19
FBS-GF 75	75	26	19	40	41	58	5	10	R 1/4"	19
FBS-GF 95	95	36	22	50	---	53	8	9	R 1/4"	19
FBS-GF 115	115	50	32	65	---	67	8	9	R 1/4"	19

**Description**

Very robust and resistant suction cup with 1,5 creases and reinforcement. Suitable for thin-walled materials with smooth or formed surface. Due to the suspension of the suction cup especially suitable for sensitive transporting goods. Antistatic design for furnishing of printed circuit boards and design in polyurethane suitable for higher wear-resistance are both available. Imprint-free design in vitone.

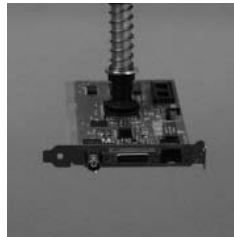

Cup GF 30 S



Cup GF 75 S



Cup GF in NBR AS, SI AS, PU with connection nipple

**Articl numbers**

Type	NBR	NBR-AS	SI-T	SI-AS	CR	PU	FKM	NR
FBS-GF 10 S	1.02.1.0160	1.02.1.0001	1.02.1.0161	1.02.1.0004	1.02.1.0162	1.02.1.0003	1.02.1.0163	1.02.1.0164
FBS-GF 15 S	1.02.1.0165	1.02.1.0006	1.02.1.0166	1.02.1.0009	1.02.1.0167	1.02.1.0008	1.02.1.0168	1.02.1.0169
FBS-GF 20 S	1.02.1.0170	1.02.1.0012	1.02.1.0171	1.02.1.0015	1.02.1.0172	1.02.1.0014	1.02.1.0173	1.02.1.0174
FBS-GF 30 S	1.02.1.0175	1.02.1.0017	1.02.1.0176	1.02.1.0020	1.02.1.0177	1.02.1.0019	1.02.1.0178	1.02.1.0179
FBS-GF 40 S	1.02.1.0180	1.02.1.0022	1.02.1.0181	1.02.1.0025	1.02.1.0182	1.02.1.0024	1.02.1.0183	1.02.1.0184
FBS-GF 50 S	1.02.1.0185	1.02.1.0027	1.02.1.0186	1.02.1.0030	1.02.1.0187	1.02.1.0195	1.02.1.0188	1.02.1.0189
FBS-GF 75 S	1.02.1.0190	1.02.1.0033	1.02.1.0191	1.02.1.0036	1.02.1.0192	1.02.1.0035	1.02.1.0193	---

1) Please order connection nipples separately; article numbers only refer to suction cup without connection nipples.

**Technical Data**

Type	Hold. force <sup>2)</sup> (N)	Weight (g)	Volume <sup>3)</sup> (ml)	Bolt typ	Conn. nipple <sup>4)</sup>	
					M5-A	R1/4-A
FBS-GF 10 S	1	1	0,01	STN-12	1.31.1.0002	---
FBS-GF 15 S	6	2	1	STN-12	1.31.1.0002	---
FBS-GF 20 S	12	5	2,5	STN-16	---	1.31.1.0005
FBS-GF 30 S	33	13	8	STN-16	---	1.31.1.0005
FBS-GF 40 S	55	19	14	STN-16	---	1.31.1.0005
FBS-GF 55 S	89	31	35	STN-16	---	1.31.1.0004
FBS-GF 75 S	197	90	100	STN-16	---	1.31.1.0006

2) Holding forces in N at 60 % operational vacuum without safety factor, on even, smooth and dry surfaces

3) Volume in released, unloaded condition of the suction cup

4) Connection nipples with other connection threads on request!

# BELLOWS TYPE CUP GF 10 - GF 75

(Perbunane, Silicone, Neoprene, Polyurethan, Vitone, Natural rubber)

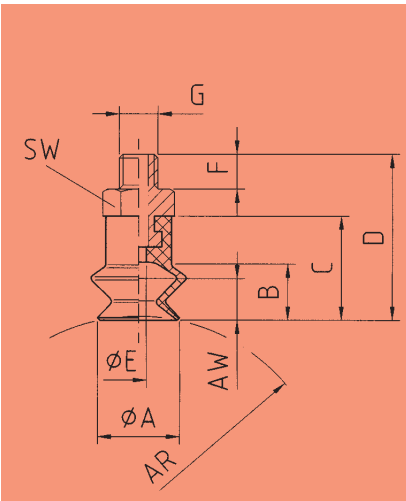

Bellows type cups GF 10 S - GF 15 S

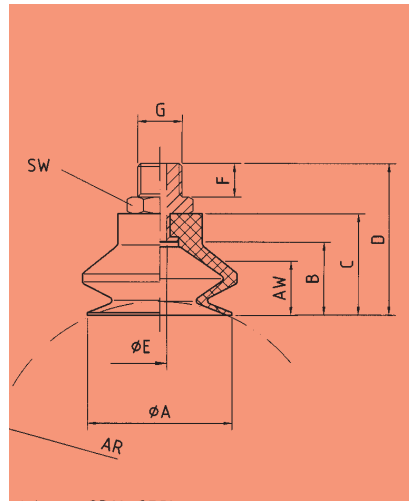

FBellows type cups GF 20 S - GF 50 S

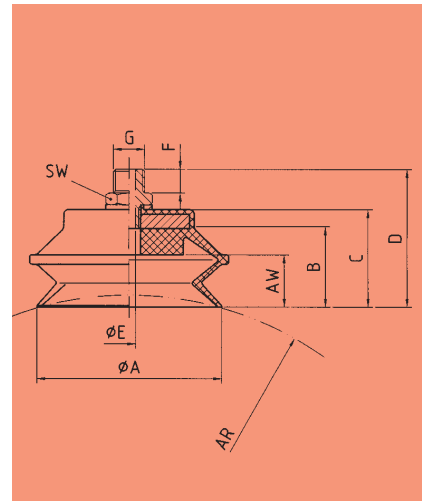

Bellows type cup GF 75 S

<b>Dimensions</b>										
Typ	A	B	AW	AR	C	D	E	F	G	SW
FBS-GF 10 S	10	7	4	5	13,5	21,5	2,5	4,5	M 5	8
FBS-GF 15 S	15	10	4	8	16	24	2,5	4,5	M 5	8
FBS-GF 20 S	20	14	9	10	22	37	3	10	G 1/4"	17
FBS-GF 30 S	30	18	13	12	30,5	45,5	4	10	G 1/4"	17
FBS-GF 40 S	40	20	12,5	20	30,5	45,5	4	10	G 1/4"	17
FBS-GF 55 S	50	25	20	25	36,5	51,5	4	10	G 1/4"	17
FBS-GF 75 S	75	34	22	35	41	58	4	10	G 1/4"	17

**Materials:**

- NBR-S Perbunane, black
- NBR-AS Perbunane antistatic, black
- SI-T Silicone, transparent
- SI-AS Silicone antistatic, black
- CR-GR Neoprene, green
- PU Polyurethane, blue
- FKM Vitone, black
- NR Natural rubber, brown

**Description**

Very robust and extremely resistant cup made of vulkollane with 1 1/2 creases. Vulkollane has an up to 10 times higher life time is especially suitable for use in multi-shift operations. Mainly suitable in automated processes and in the plastic and packing industries. After they are worn out they can be easily removed from the connection nipple and replaced.

Design -ÖN with special oil groove for high cross forces.



GF 85 VU-ÖN with oil groove



Bellows type cup GF 20 VU - GF 85 VU made of vulkollane

**Materials:**

VU-BR Vulkollane, brown

**Article numbers**

Type	VU-BR	conn. nipple 1/4-A
FS-GF 20 VU	1.02.1.0100	1.31.1.0021
FS-GF 30 VU	1.02.1.0101	1.31.1.0021
FS-GF 40 VU	1.02.1.0102	1.31.1.0020
FS-GF 40 VU-ÖN	1.02.1.0103	1.31.1.0020
FS-GF 50 VU	1.02.1.0104	1.31.1.0019
FS-GF 60 VU	1.02.1.0105	1.31.1.0022
FS-GF 60 VU-ÖN	1.02.1.0106	1.31.1.0022
FS-GF 85 VU	1.02.1.0107	1.31.1.0022
FS-GF 85 VU-ÖN	1.02.1.0108	1.31.1.0022

1) Please order connection nipples separately; article numbers only refer to suction cup without connection nipples.

**Technical Data**

Type	Hold. force <sup>2)</sup> (N)	Weight (g)	Volume <sup>3)</sup> (ml)	Bolt type
FS-GF 20 VU	25	8	2,8	STN-16
FS-GF 30 VU	39	15	6,5	STN-16
FS-GF 40 VU	73	21	13	STN-16
FS-GF 40 VU-ÖN	75	20	15	STN-16
FS-GF 50 VU	106	28	28	STN-16
FS-GF 60 VU	160	39	34	STN-16
FS-GF 60 VU-ÖN	170	35	38	STN-16
FS-GF 85 VU	220	98	92	STN-16
FS-GF 85 VU-ÖN	230	90	98	STN-16

2) Holding forces in N at 60 % operational vacuum without safety factor, on even, smooth and dry surfaces

3) Volume in released, unloaded condition of the suction cup

**Vulkollane**

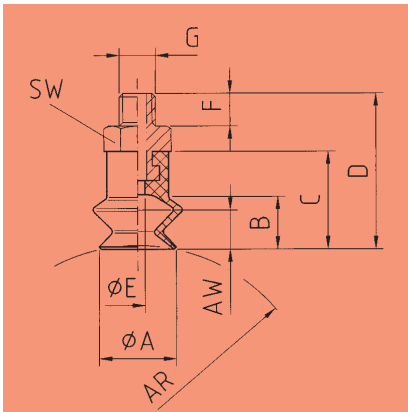

Bellows type cups GF 20 - GF 30 VU

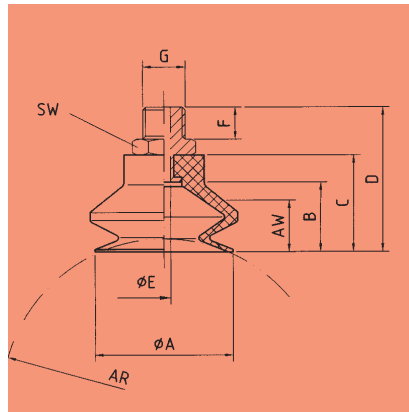

Bellows type cups GF 40 - GF 85 VU

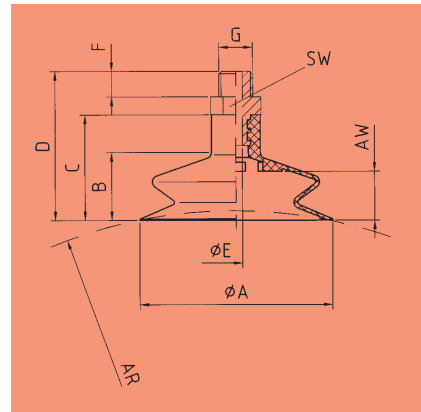

Bellows type cups GF 40, 60 and 85 VU-ÖN

**Suction cup 2**

<b>Dimensions</b>										
Type	A	B	AW	AR	C	D	E	F	G	SW
FS-GF20VU	20	7	13	10	18	30	6	12	G 1/4	19
FS-GF30VU	30	7	13	12	22	34	6	12	G 1/4	19
FS-GF40VU	40	12	17	20	30	47	6	12	G 1/4	19
FS-GF40VU-ÖN	40	12	17	20	30	47	6	12	G 1/4	19
FS-GF50VU	51	17	24	30	41	59	6	10	G 1/4	17
FS-GF60VU	60	20	28	40	40	55	6	10	G 1/4	19
FS-GF60VU-ÖN	60	20	16	40	40	55	6	10	G 1/4	19
FS-GF85VU	85	20	26	50	57	72	6	10	G 1/4	19
FS-GF85VU-ÖN	85	20	26	50	57	72	6	10	G 1/4	19

(Perbunane, Silicone, Neoprene, Polyurethan, Vitone, Natural rubber)

**Beschreibung**

Very robust and resistant suction cup with 2.5 creases. Suitable for thin-walled materials with smooth or formed surface. Because of the suspension of the suction cup especially suitable for sensitive transporting goods. Because of the elasticity of the creases the suction cup adjusts to the work piece in every situation. Creases pull together when suction process is activated (relatively high suction way).



Cup GFD 30



GFD 90 w/ conn. nipple



Cup GFD w/ connection nipple

Suction cup 2

**Article numbers**

Type	NBR	NBR-AS	SI-T	SI-AS	CR	PU-B	FKM	NR
FBS-GFD 5	1.02.1.0116	1.02.1.0117	1.02.1.0118	1.02.1.0119	1.02.1.0120	1.02.1.0121	---	1.02.1.0122
FBS-GFD 7	1.02.1.0123	1.02.1.0124	1.02.1.0125	1.02.1.0126	1.02.1.0127	1.02.1.0128	---	1.02.1.0129
FBS-GFD 10	1.02.1.0038	1.02.1.0130	1.02.1.0040	1.02.1.0131	1.02.1.0132	1.02.1.0039	---	1.02.1.0133
FBS-GFD 15	1.02.1.0041	1.02.1.0134	1.02.1.0043	1.02.1.0135	1.02.1.0136	1.02.1.0042	---	1.02.1.0137
FBS-GFD 18	1.02.1.0138	1.02.1.0139	1.02.1.0140	1.02.1.0141	1.02.1.0142	1.02.1.0143	1.02.1.0144	1.02.1.0145
FBS-GFD 20	1.02.1.0044	1.02.1.0146	1.02.1.0046	1.02.1.0147	1.02.1.0148	1.02.1.0045	1.02.1.0149	1.02.1.0150
FBS-GFD 30	1.02.1.0047	1.02.1.0151	1.02.1.0049	1.02.1.0152	1.02.1.0153	1.02.1.0048	1.02.1.0154	1.02.1.0155
FBS-GFD 40	1.02.1.0050	1.02.1.0156	1.02.1.0052	1.02.1.0157	1.02.1.0158	1.02.1.0051	---	1.02.1.0159
FBS-GFD 60	1.02.1.0056	---	1.02.1.0058	---	---	1.02.1.0057		
FBS-GFD 90	1.02.1.0059	---	1.02.1.0061	---	---	---		

1) Please order connection nipples separately; article numbers only refer to suction cup without conn. nipples.

**Technical Data**

Type	Hold. force <sup>2)</sup> (N)	Weight (g)	Volume <sup>3)</sup> (ml)	Bolt type	Conn. nipple	
					M5-A	R1/4-A
FBS-GFD 5 S				STN-12	1.31.1.0002	---
FBS-GFD 7 S				STN-12	1.31.1.0002	---
FBS-GFD 10 S	1	4	0,4	STN-12	1.31.1.0003	---
FBS-GFD 15 S				STN-12	1.31.1.0003	---
FBS-GFD 18 S	6	4	1	STN-12	1.31.1.0003	---
FBS-GFD 20 S	13	5	2,5	STN-12	1.31.1.0003	---
FBS-GFD 30 S	30	34	10	STN-16	---	1.31.1.0005
FBS-GFD 40 S	51	40	19	STN-16	---	1.31.1.0005
FBS-GFD 60 S	96	80	55	STN-16	---	1.31.1.0005
FBS-GFD 90 S	246	198	140	STN-16	---	1.31.1.0008

2) Holding forces in N at 60 % operational vacuum without safety factor, on even, smooth and dry surfaces

3) Volume in released, unloaded condition of the suction cup

# FALTENBALGSAUGER GFD 5 - GFD 90

(Perbunane, Silicone, Neoprene, Polyurethane, Vitone, Natural rubber)

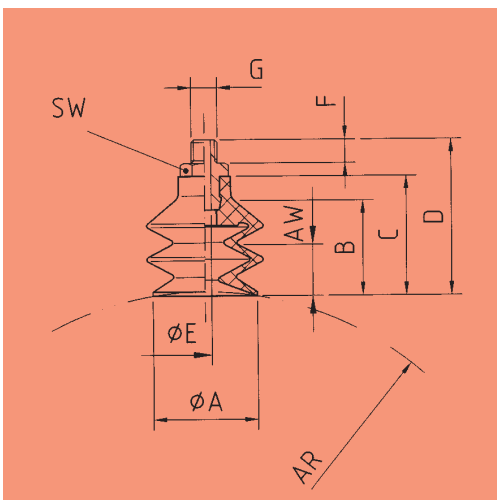

Cup GFD 10 - GFD 20

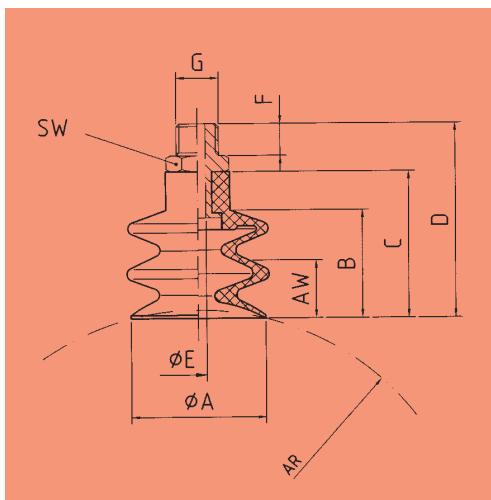

Cup GFD 30 - GFD 90

**2**  
Suction cup

<b>Dimensions</b>										
Type	A	B	AW	AR	C	D	E	F	G	SW
FBS-GFD 5 S	5	6	3	---	10	18	2,5	4,5	M 5	8
FBS-GFD 7 S	7	6	3	---	10	18	2,5	4,5	M 5	8
FBS-GFD 10 S	9	8	3	4	15	22	3,5	4,5	M 5	8
FBS-GFD 15 S	14	16	7	6	23	30	3,5	4,5	M 5	8
FBS-GFD 18 S	18	16	8	7	23	30	3,5	4,5	M 5	8
FBS-GFD 20 S	20	17,5	9	8	23	30	3,5	4,5	M 5	8
FBS-GFD 30 S	32	26	14	10	37,5	52,5	3,5	10	G 1/4"	17
FBS-GFD 40 S	42	34	17	15	46	61	3,5	10	G 1/4"	17
FBS-GFD 60 S	62	50	23	25	55	70	3,5	10	G 1/4"	17
FBS-GFD 90 S	88	76	27	50	87,5	102,5	3,5	10	G 1/4"	17

**Materials:**

- NBR-S Perbunane, black
- NBR-AS Perbunane antistatic, black
- SI-T Silicone, transparent
- SI-AS Silicone antistatic, black
- CR-GR Neoprene, green
- PU Polyurethane, blue
- FKM Vitone, black
- NR Natural rubber, brown

**Description**

Very robust and extremely resistant cup made of vulkollane with 2 1/2 creases. Vulkollane has an up to 10 times higher life time is especially suitable for use in multi-shift operations. Mainly suitable in automated processes and in the plastic and packing industries. After they are worn out they can be easily removed from the connection nipple and replaced. Design -ÖN with special oil groove for high cross forces.



Cup GFD 20 VU - GFD 85 VU made of vulkollane

**Suction cup 2**

**Materials:**

VU-BR Vulkollane, brown

<b>Article numbers</b>		
Type	VU-BR	conn. nipple 1/4-A
FS-GFD 20 VU	1.02.1.0110	1.31.1.1.0021
FS-GFD 30 VU	1.02.1.0111	1.31.1.1.0021
FS-GFD 50 VU	1.02.1.0112	1.31.1.1.0020
FS-GFD 60 VU	1.02.1.0113	1.31.1.1.0020
FS-GFD 85 VU	1.02.1.0114	1.31.1.1.0022
FS-GFD 85 VU-ÖN	1.02.1.0115	1.31.1.1.0022

1) Please order connection nipples separately; article numbers only refer to suction cup without conn. nipples.

<b>Technische Daten</b>				
Typ	Haltekraft <sup>2)</sup> (N)	Gewicht (g)	Volumen <sup>3)</sup> (ml)	Stößel- typ
FS-GFD 20 VU	24	19	4,0	STN-16
FS-GFD 30 VU	38	24	11	STN-16
FS-GFD 50 VU	95	31	48	STN-16
FS-GFD 60 VU	150	42	63	STN-16
FS-GFD 85 VU	280	112	170	STN-16
FS-GFD 85 VU-ÖN	290	112	170	STN-16

2) Holding forces in N at 60 % operational vacuum without safety factor, on even, smooth and dry surfaces

3) Volume in released, unloaded condition of the suction cup

**Vulkollane**

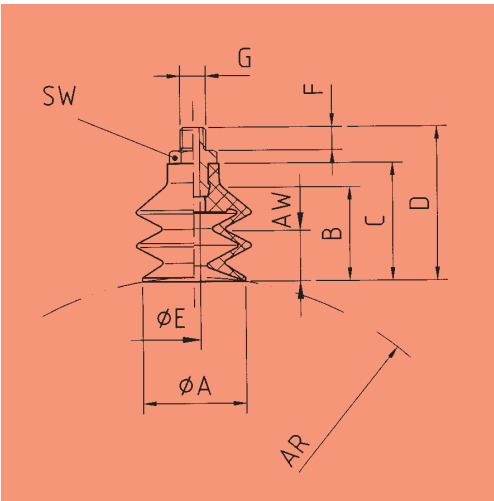

Cups GFD 20 - GFD 30 VU

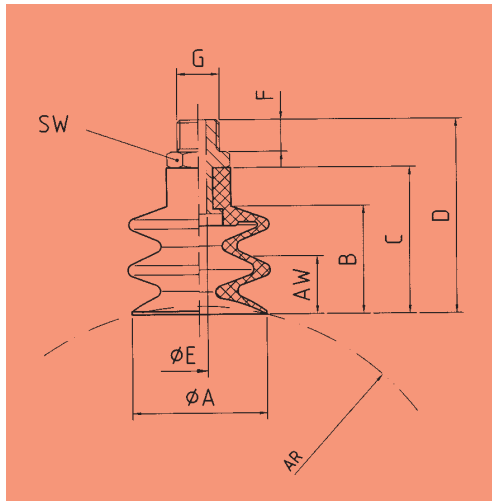

Cups GFD 50 - GFD 85 VU

**2**  
Suction cup

<b>Dimensions</b>										
Type	A	B	AW	AR	C	D	E	F	G	SW
FS-GFD 20 VU	20	18	16	10	25	37	6	12	G 1/4	19
FS-GFD 30 VU	30	25	16	12	32	44	6	12	G 1/4	19
FS-GFD 50 VU	51	35	20	20	45	62	6	12	G 1/4	19
FS-GFD 60 VU	60	55	31	25	70	87	6	12	G 1/4	19
FS-GFD 85 VU	85	61	41	50	81	96	6	10	G 1/4	19
FS-GFD 85 VU-ÖN	85	61	41	50	81	96	6	10	G 1/4	19